



Salice Paolo

# MODERNO *MODERN*

La gamma moderna Salice Paolo è in pieno fermento. Nuovi brevetti e designer puntano ad affermare il marchio oltre la sua riconosciuta eccellenza nel settore classico. Lo stile sobrio non deve essere anonimo: ogni modello è pensato per completare ed arricchire il suo ambiente ideale. Avvicinandovi ad un modello Salice Paolo noterete sempre un dettaglio, qualcosa che sfugge ad un primo sguardo.

*The modern range Salice Paolo is in full swing. New patents and new designers are aiming to establish the brand beyond its recognized excellence in the classic field. The simple style should not be anonymous: each model is designed to complement and enrich its ideal environment. As you approach a Salice Paolo model you will always notice a detail, something that escapes at first glance.*



# SAND

Manuela Bucci e Davide Diliberto



# SAND



CRS



GR



FLA

### Finiture Finishes

CR

CRS

GR

FLA

6145

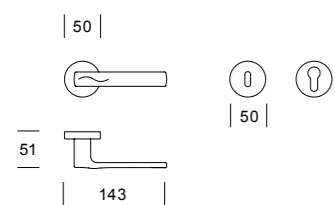

6148

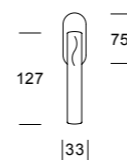

6147

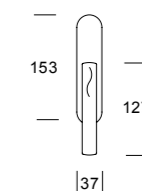

6146

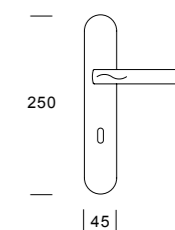





# MABELLE

Manuela Bucci e Davide Diliberto



6150

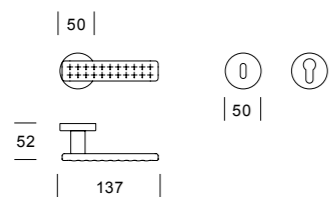

### Finiture Finishes

CR

CRS

GR

FL



# MABELLE



6153

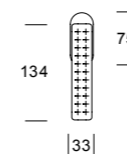

CRS



GR



FLA

6152

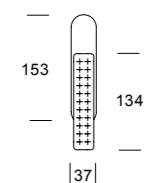

6151

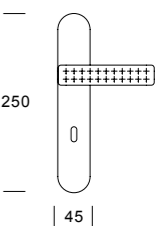



# PAGE

Architetti Associati  
Carlo Marelli Massimo Molteni



# PAGE



CRS



GR



SBO



H2



H1



G1



G3

### Motivi decorativi - Colori Decorative motifs - Colours



H

1-Beige



G

2-Grigio / Grey

3-Oro / Gold

### Finiture Finishes

CR

CRS

GR

SBO

6125

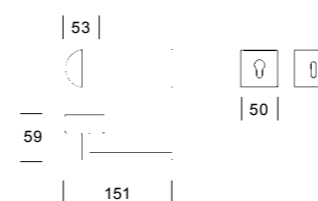





3336

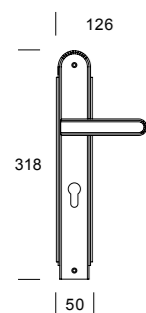

3335

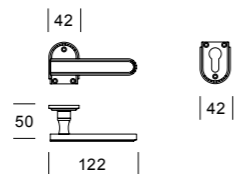

3336/S

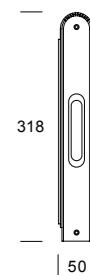





# EDGE

Manuela Bucci e Davide Diliberto



# EDGE



CRS



GR

6140

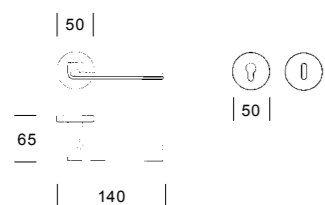

### Finiture Finishes

CR

CRS

GR

6143

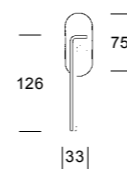

6142

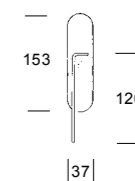

6141

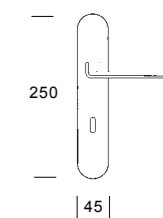



# TUBE

Architetti Associati  
Carlo Marelli Massimo Molteni



**6135**

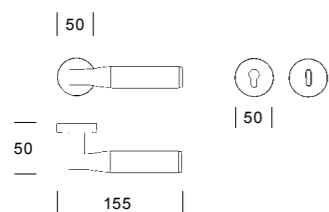

### Finiture Finishes

CR

CRS

CRS/CRS

CRS/CR

GR



# TUBE



**6138**

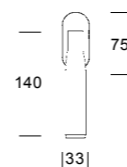

**6137**

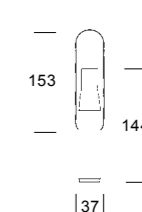

**6136**

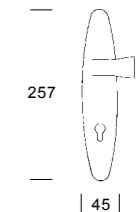



# TUBE

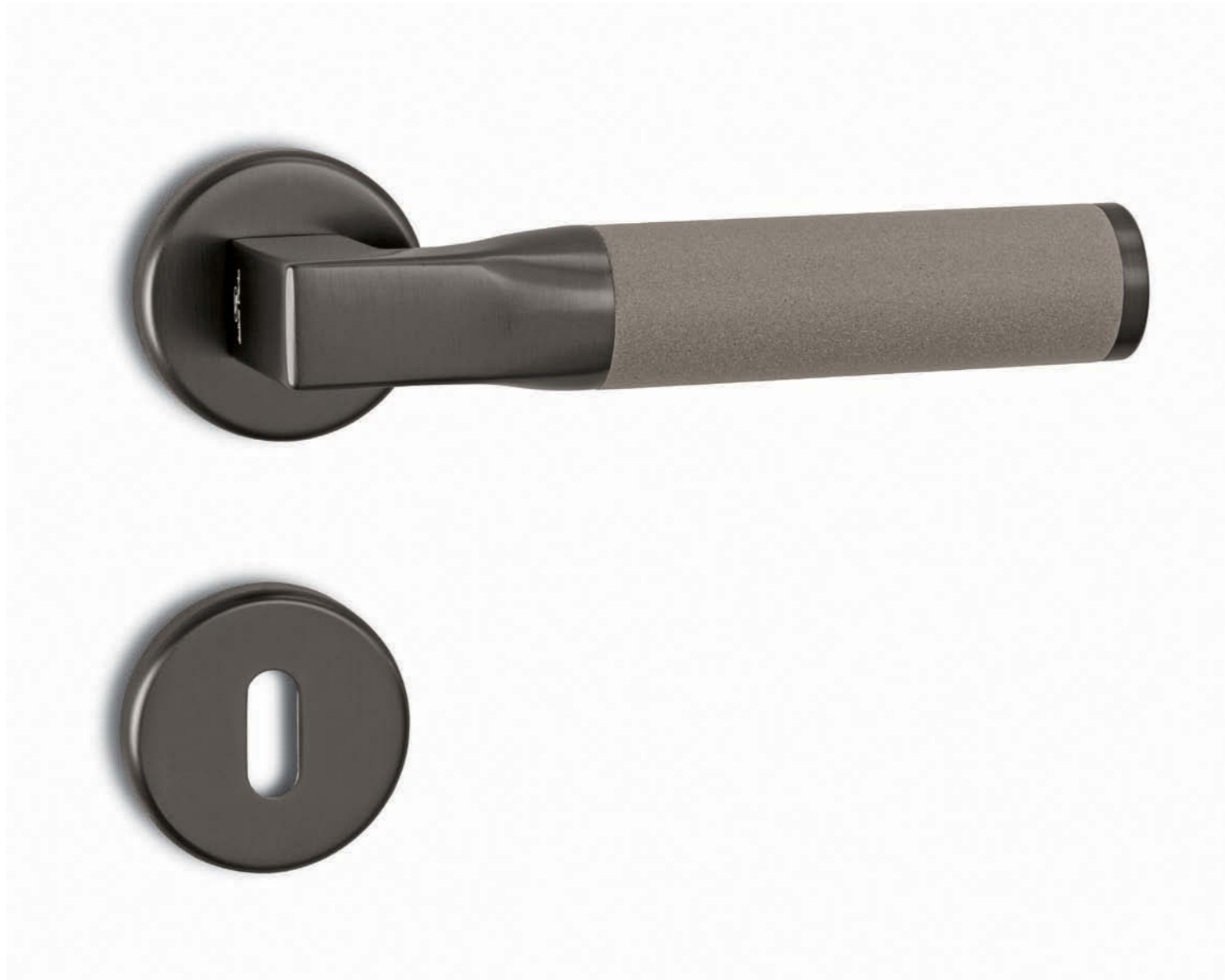

# TUBE



### Finiture Finishes

CR		SD
CRS	+	ST
GR		W
		Z



# WAVE

Architetti Associati  
Carlo Marelli Massimo Molteni



# WAVE



CRS



GR

6130

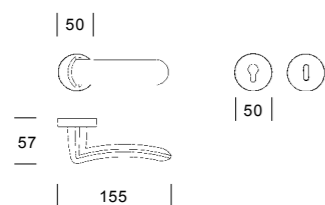

### Finiture Finishes

CR

CRS

GR

6133

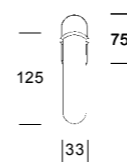

6132

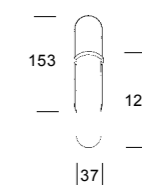

6131

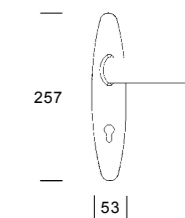





**6060**

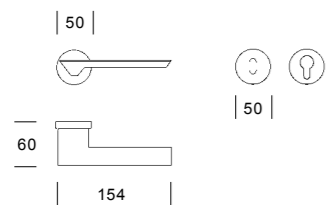

**Finiture  
Finishes**

- CR
- CRS
- GR
- NS



**6063**

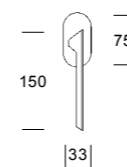

CRS



NS

**6062**

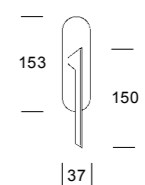

**6061**

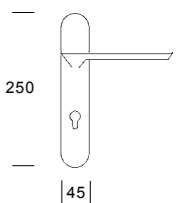



# CEDRO SQ

Studio Galeazzi & Associati



# CEDRO SQ



CRS



NS

### Finiture Finishes

- CR
- CRS
- GR
- NS

6075

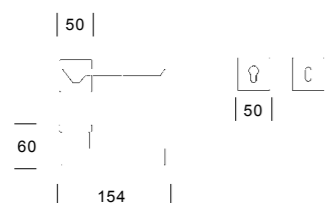

6078

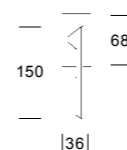

6077

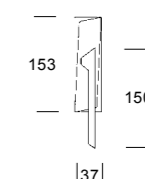

6076

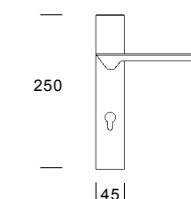

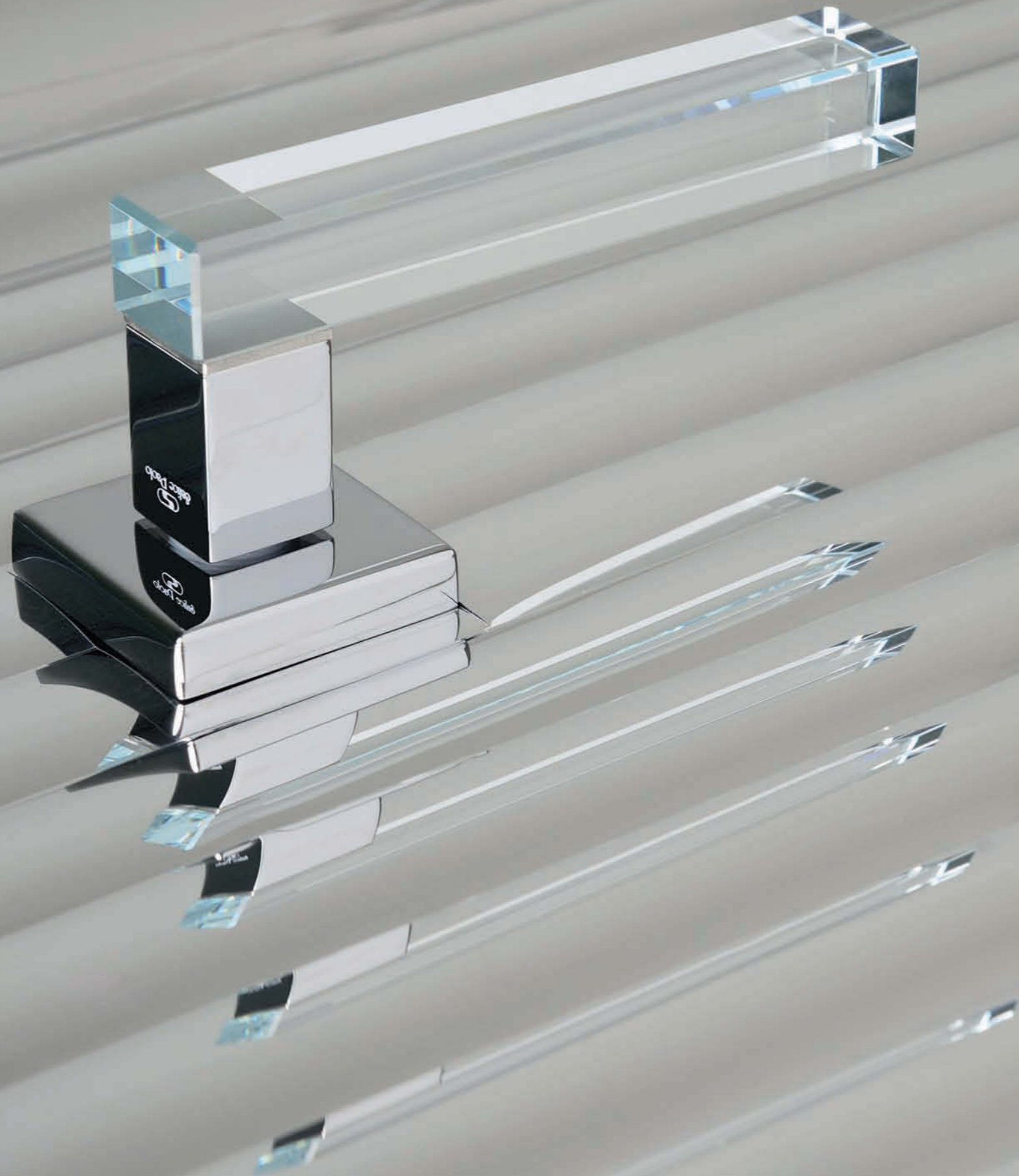





# SHINY

Studio Galeazzi & Associati



# SHINY



CRS

NS

**6085**

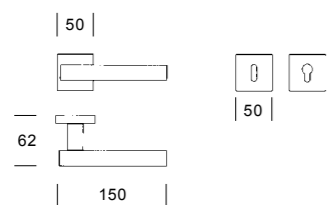

**Finiture  
Finishes**



CR

CRS

NS

**6088**



**6087**

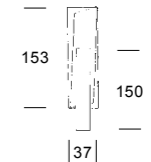

**6086**

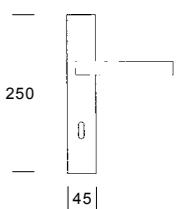



# PLISSÉ

Arch. Enrico Marforio  
e arch. Daniele Moro



# PLISSÉ



CR



NS

**6100**

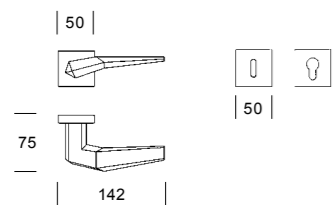

### Finiture Finishes

CR

CRS

NS

**6103**

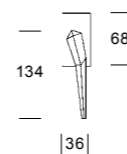

**6102**

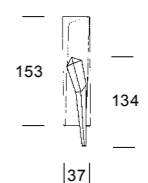

**6101**

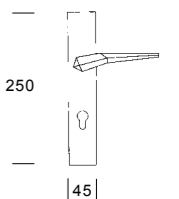



**LINK**

Anna Deplano



**LINK**



**6115**

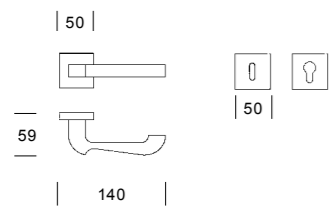

**Finiture  
Finishes**

- CR
- CRS
- NS

**6118**

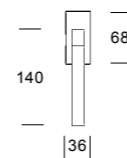

**6117**

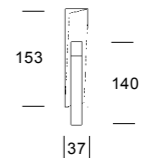

**6116**

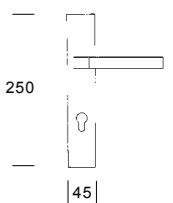





# ANATOMICA

Studio 6A



# ANATOMICA



CRS



NS

4870

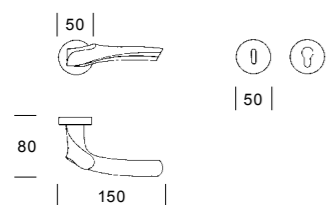

### Finiture Finishes

CR

CRS

NS

4873/BIS

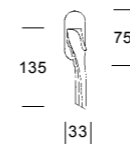

4872

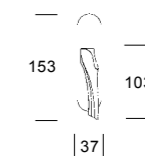

4871

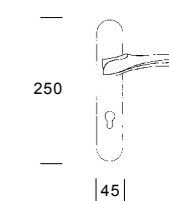



# ANATOMICA SQ

Studio 6A



# ANATOMICA SQ



CRS



NS

6105

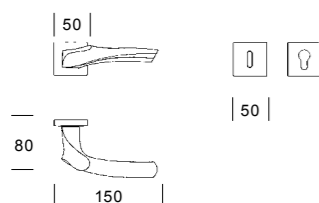

### Finiture Finishes

CR

CRS

NS

GR

6108

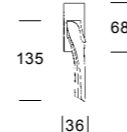

6107

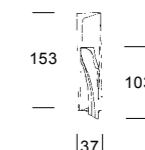

6106

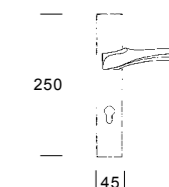



# PAPILLON

Studio Galeazzi & Associati



# PAPILLON



NS

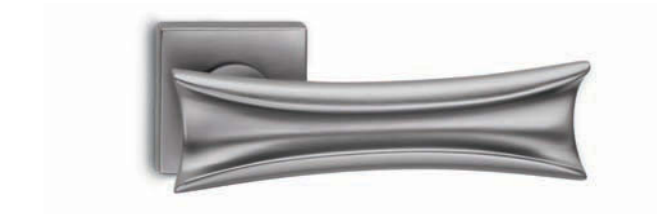

CRS

**6095**

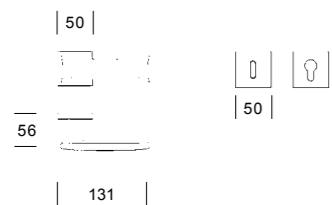

### Finiture Finishes

CR

CRS

NS

CRS/CR

**6098**



**6097**

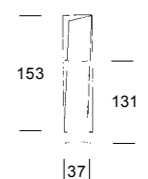

**6096**

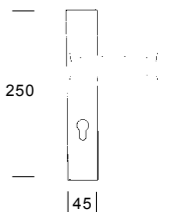



ZEN

Riccardo Arbizioni

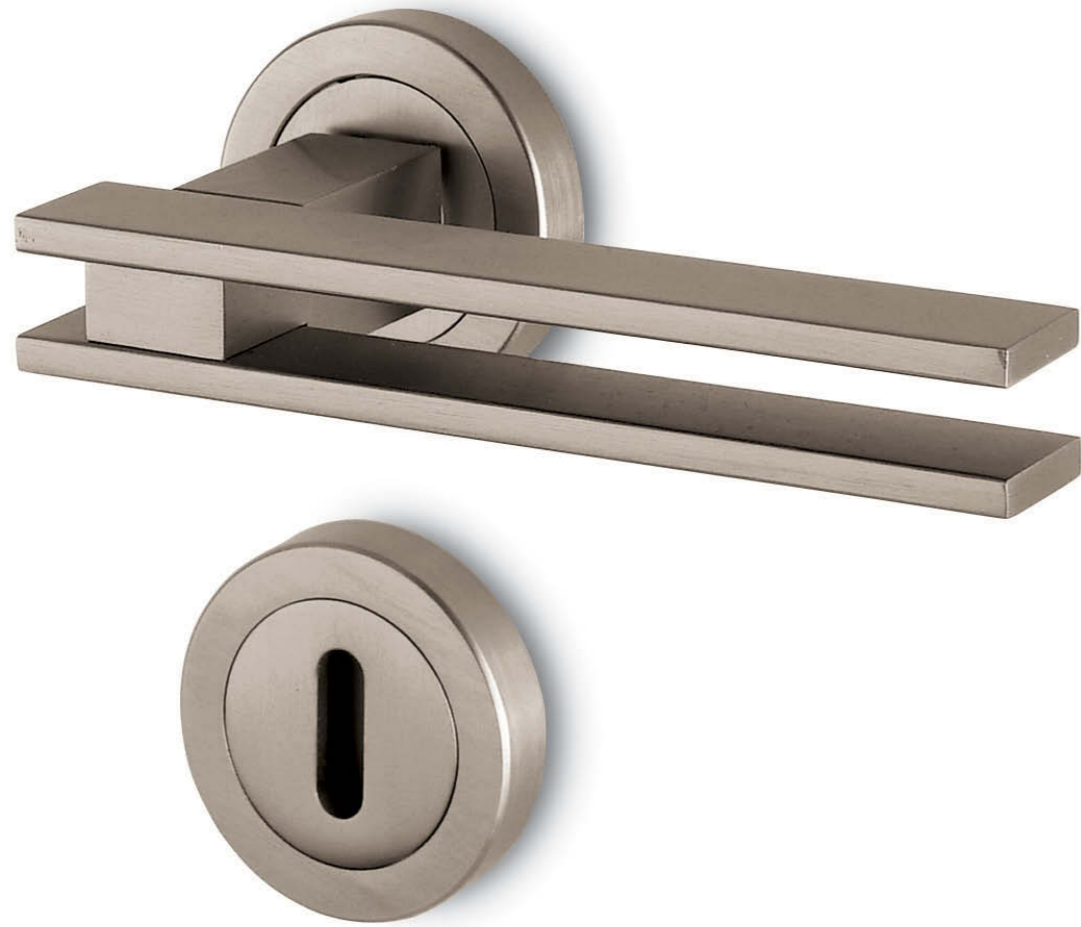

6025

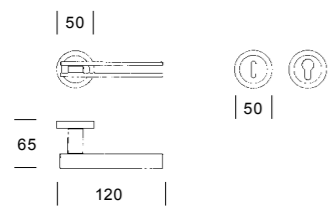

**Finiture  
Finishes**

- CR
- CRS
- NS

6028

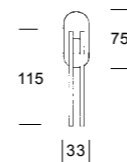

ZEN



CR



CRS

6027

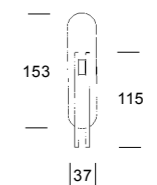

6026

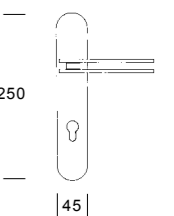





# ZEN SQ

Riccardo Arbizioni



# ZEN SQ



CRS

NS

6080

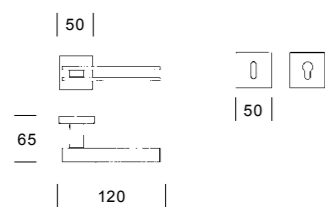

### Finiture Finishes

CR

CRS

NS

6083

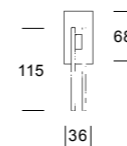

6082

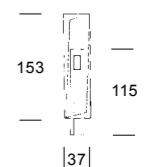

6081

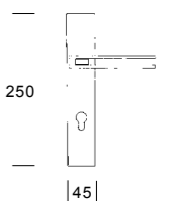



# CAMELIA

Renzo Morini



# CAMELIA



CRS



NS

**4830**

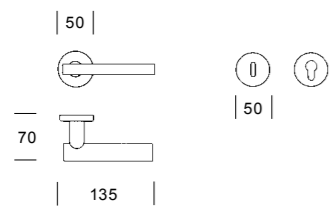

### Finiture Finishes

CR

CRS

NS

**4833/BIS**

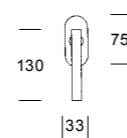

**4832**

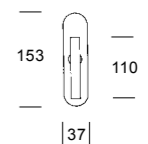

**4831**

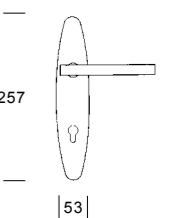



# FLAP

Arch. Enrico Marforio  
e arch. Daniele Moro



**6110**

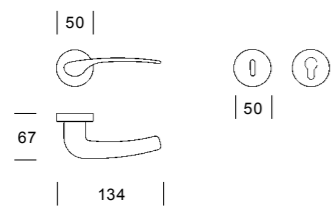

### Finiture Finishes

CR

CRS

NS

OL

**6113**

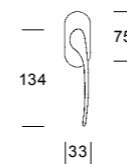

# FLAP



CRS

NS

**6112**

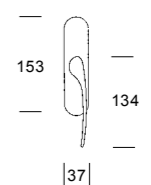

**6111**

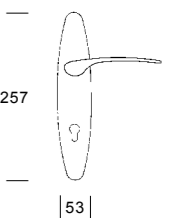



# SCILLA

Riccardo Arbizioni



# SCILLA



### Finiture Finishes

CR

CRS

NS

CR/CRS

4850

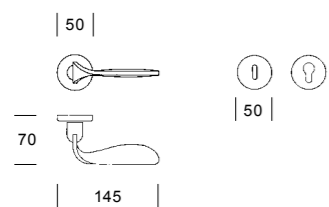

4853/BIS

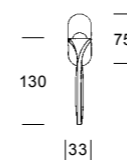

4852

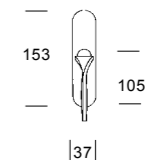

4851

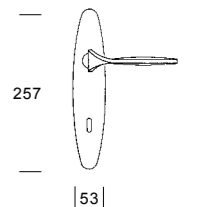



# CELSIA

Riccardo Arbizioni



# CELSIA



CRS



NS

**4840**

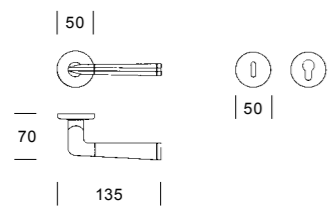

**Finiture  
Finishes**

- CR
- CRS
- NS

**4843/BIS**

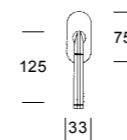

**4842**

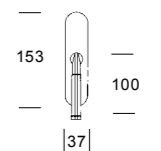

**4841**

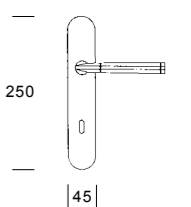



CRS



NS

**Finiture  
Finishes**

CR

CRS

OL

NS

OD

**6010**

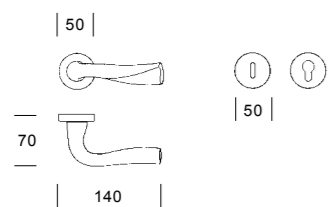

**6013/BIS**

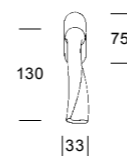

**6012**

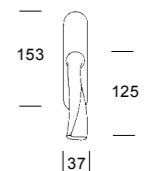

**6011**

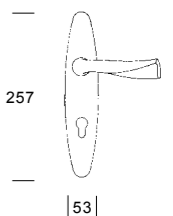



# DAFNE

Studio Salice Paolo

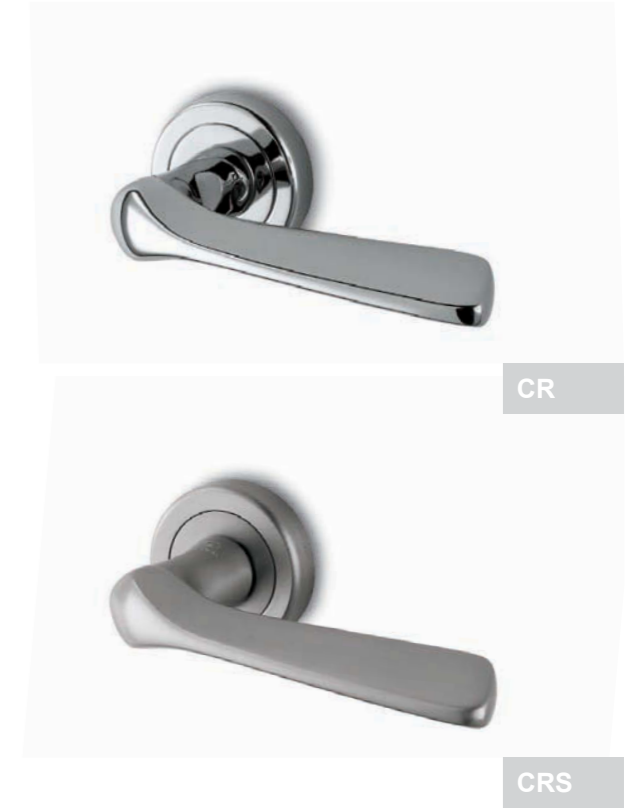

### Finiture Finishes

- CR
- CRS
- OL
- NS

**6020**

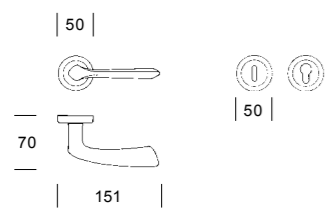

**6023**

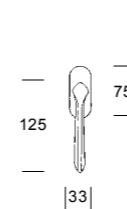

**6022**

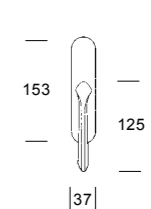

**6021**

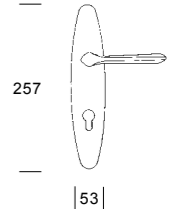



# TULIPANO

Arch. Enrico Marforio



# TULIPANO



CR



CRS



NS

### Finiture Finishes

CR

CRS

OL

NS

6015

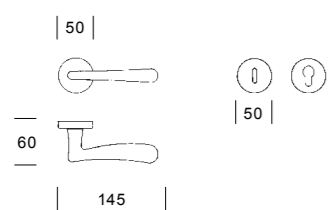

6018/BIS

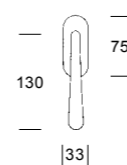

6017

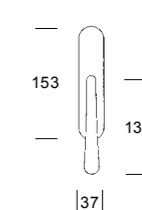

6016

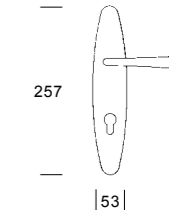





**ILEX**  
Studio Salice Paolo



**ILEX**



CR



NS

**Finiture  
Finishes**

CR

CRS

OL

NS

**6005**

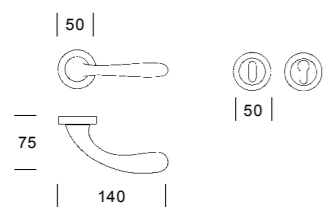

**6008/BIS**

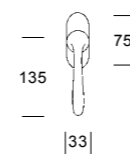

**6007**

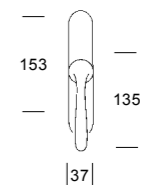

**6006**

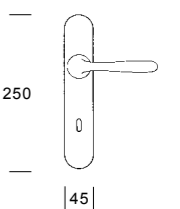



# TIMO

Studio Sandini & Associati



# TIMO



CRS/CR



NS/NL

6050

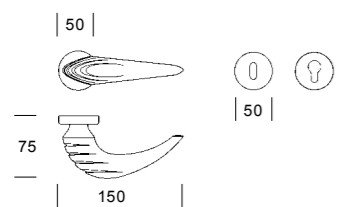

### Finiture Finishes

CR

CRS/CR

NS/NL

6053

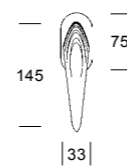

6052

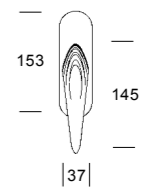

6051

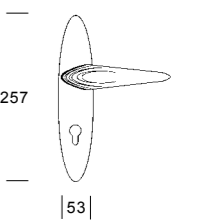





# DIAMANTE

Studio Salice Paolo

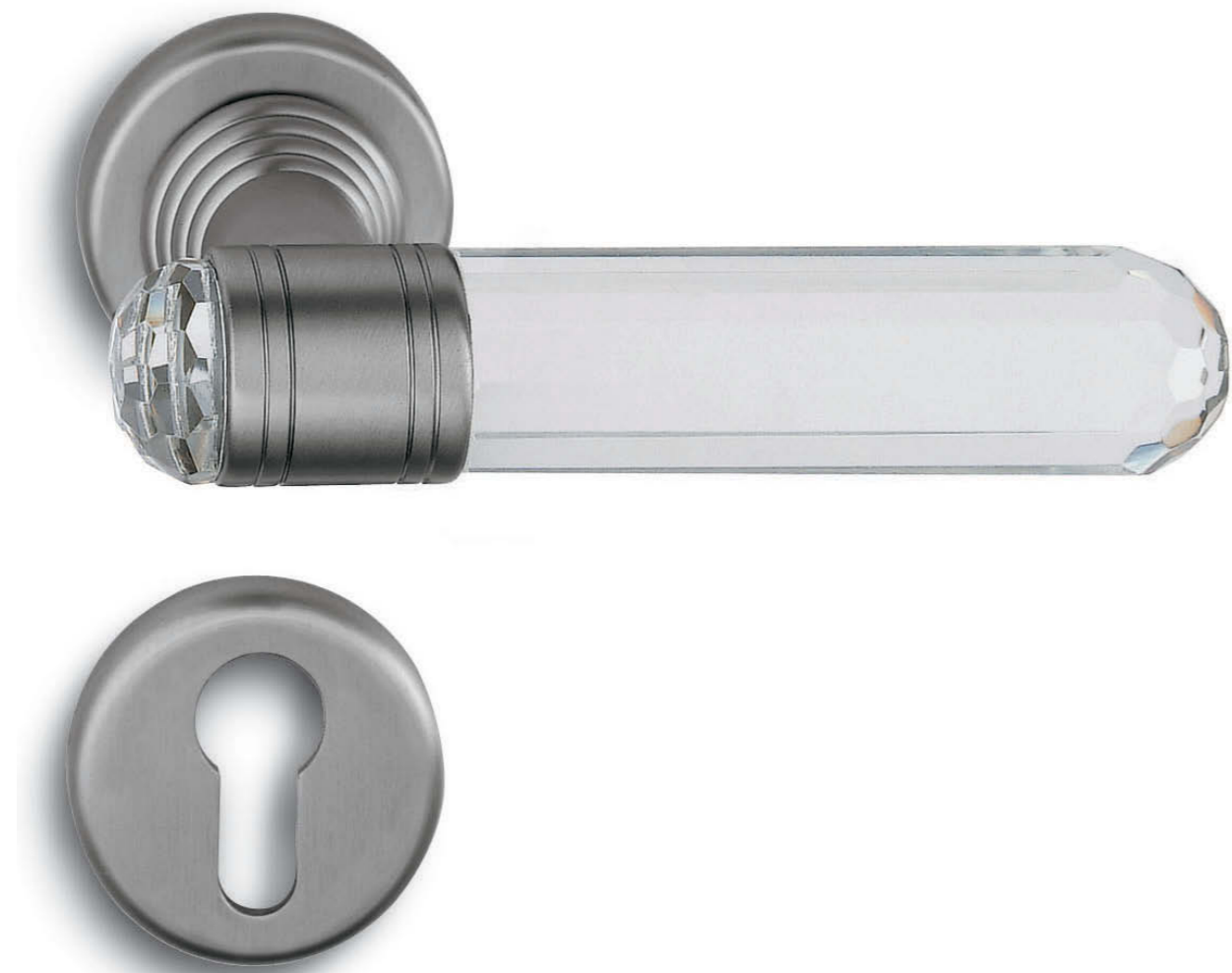

# DIAMANTE



CRS

### Finiture Finishes



- CR
- CRS
- DOR
- OL

4480

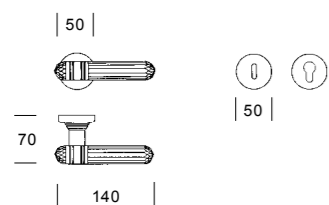

4483/BIS

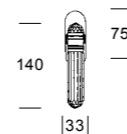

4482

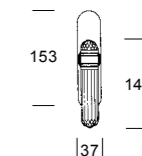

4481

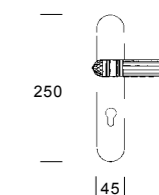



# ARTEMISIA

Studio Salice Paolo



# ARTEMISIA



CR

**4820**

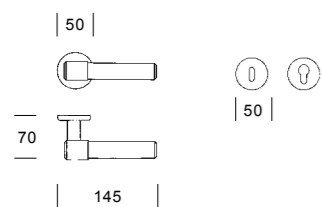

**Finiture  
Finishes**



CR

CRS

OL

**4823/BIS**

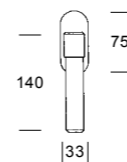

**4822**

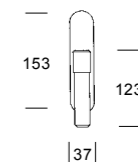

**4821**

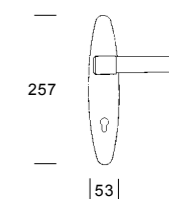



# ACHILLEA

Studio Salice Paolo



# ACHILLEA



CRS



NS

14480

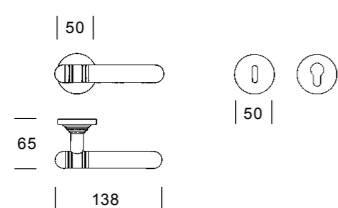

### Finiture Finishes



CR

CRS

NS

14483/BIS

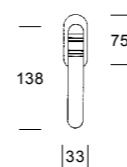

14482

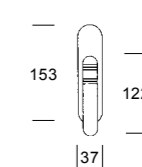

14481

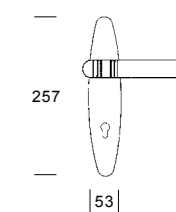



# MANIGLIONI *DOORPULL*





# CEDRO

Studio Galeazzi & Associati



# TUBE

Architetti Associati  
Carlo Marelli Massimo Molteni



6064

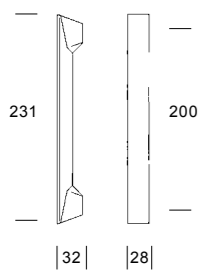

### Finiture Finishes

CR

CRS

NS

6139

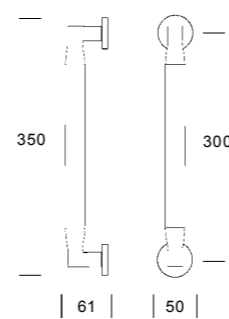

### Finiture Finishes

CR

CRS

GR

CR/CRS

CRS/CR

CR

CRS

GR

SD

ST

Z

+





# ANATOMICA

Studio 6A



4874

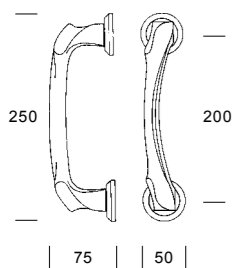

### Finiture Finishes

CR

CRS

NS



# ANATOMICA SQ

Studio 6A



6109

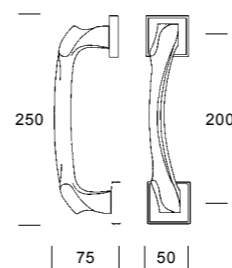

### Finiture Finishes

CR

CRS

GR

NS



# ZEN

Riccardo Arbizioni



# ZEN SQ

Riccardo Arbizioni



6029/A

6029/B

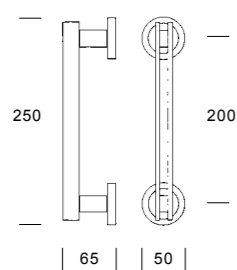
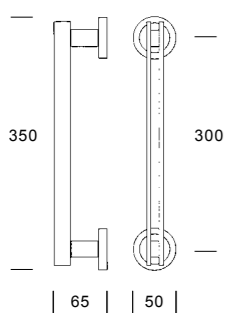

6084/A

6084/B

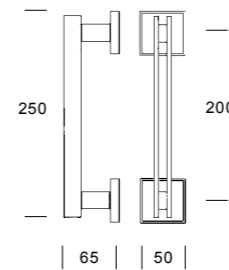
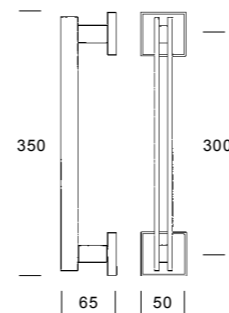

### Finiture Finishes

CR

CRS

NS

### Finiture Finishes

CR

CRS

GR

NS



# LINK

Anna Deplano



### Finiture Finishes

CR

CRS

NS

6119/A

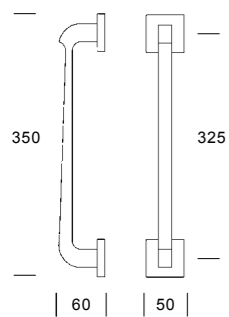

# TIMO

Studio Sandini & Associati



### Finiture Finishes

CR

CR/SCR

NS/NL

6054/A

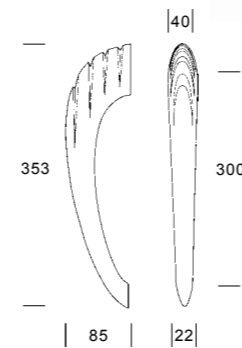



# DIAMANTE

Studio Salice Paolo



4484

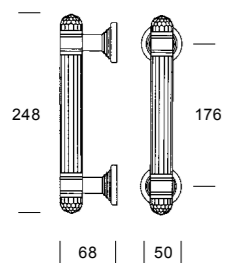

### Finiture Finishes

- CR
- CRS
- DOR
- OL



# IPOMEA

Studio Salice Paolo



4824

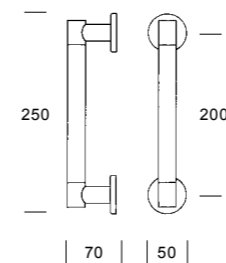

### Finiture Finishes

- CR
- CRS
- OL



# ARNICA

Studio Salice Paolo



4473/A

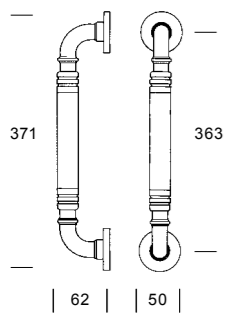

4473/B

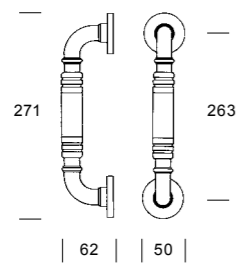

### Finiture Finishes

- CR
- CRS

4834

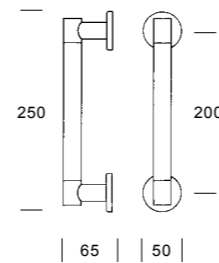

# BEGONIA

Renzo Morini



### Finiture Finishes

- CR
- CRS
- NS





# PATCH

Manuela Bucci e Davide Diliberto



# PATCH



CR

CRS

GR

5301SWC

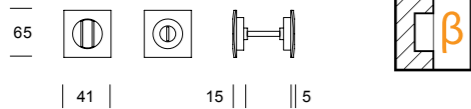

### Finiture Finishes

CR

CRS

GR

5301S



5301SCF

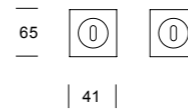

5301SY

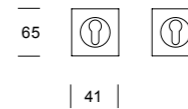

5301SWCN

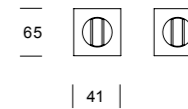



**Finiture**  
*Finishes*

CR

CRS

ETR

OL

OD

PVD

GR

NS

**Finiture**  
*Finishes*

CR

CRS

GR

NS

4488

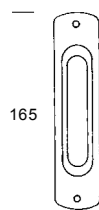

| 35 |

| 15 |

4909

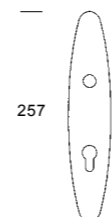

| 53 |

4910

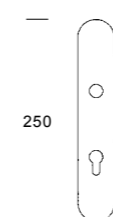

| 45 |

4911

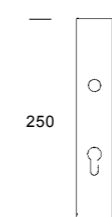

| 45 |







# FRESIA

Riccardo Arbizzoni

Stile: Fine 800



# FRESIA



3256

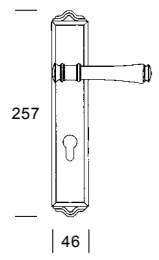

### Finiture Finishes

DOR 24K

ETR

OL

D

3255

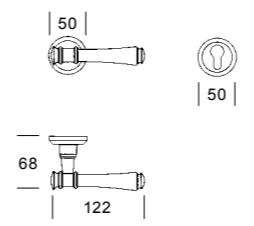

3258/BIS

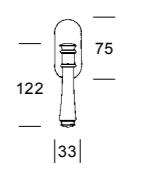

3257

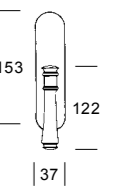



# CASSIA

Riccardo Arbizzoni

Stile: Fine 800



# CASSIA



3251

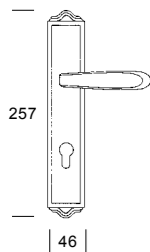

### Finiture Finishes

DOR 24K

ETR

OL

D

3250

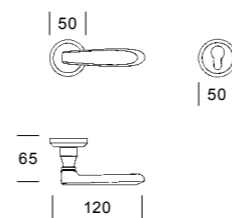

3253/BIS

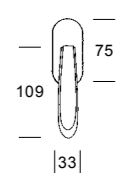

3253

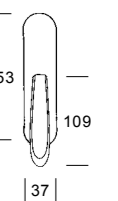



# MEDINA

Stile: Art Déco



# MEDINA



4206

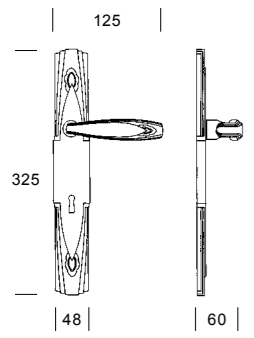

4205

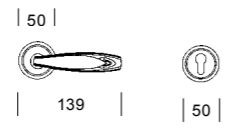

4206/S

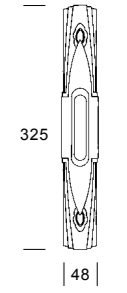



# BERLINO

Stile: 700 tedesco



# BERLINO



4391

4390

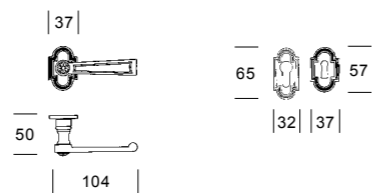

4391/S

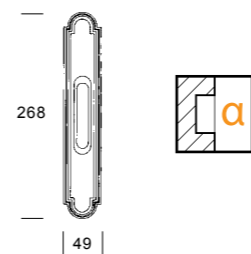

4392

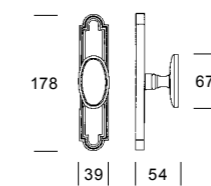

4392/4390





# MADRID

Stile: Vittoriano



# MADRID



4416

4416/S

4417

4417/4415

4415

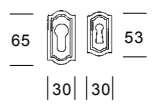
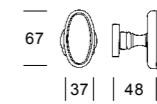
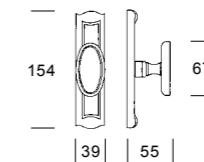
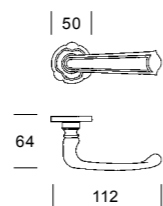
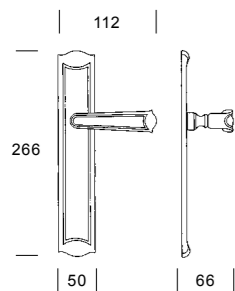



# MANIGLIONI DOORPULL



Stile: Coloniale



Stile: Coloniale



4326

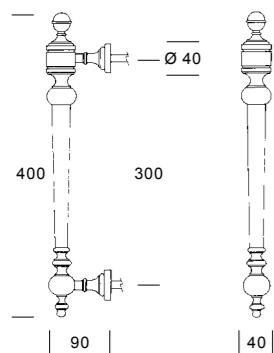

3033

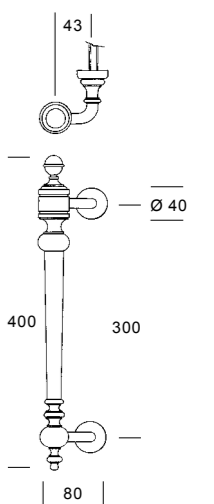





Stile: Fine '800



# SNAKE



3035

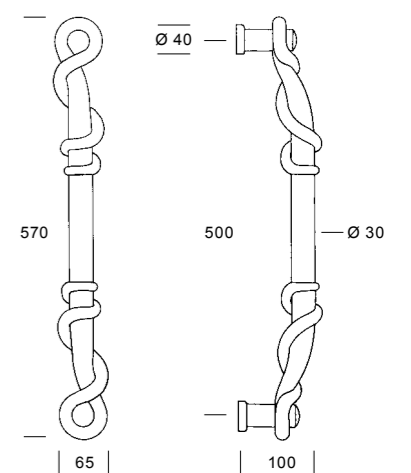



# BOMBAY

Stile: Chippendale



Stile: Chippendale



# KARACHI



3036

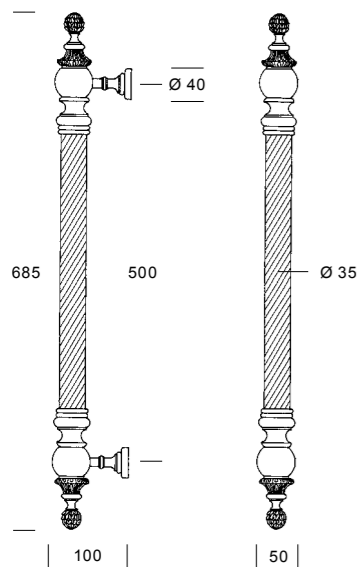

3070

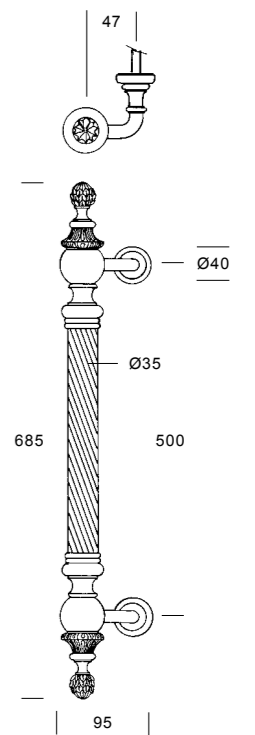



# ISTAMBUL

Stile: Chippendale



Stile: Chippendale



# ANKARA



4328

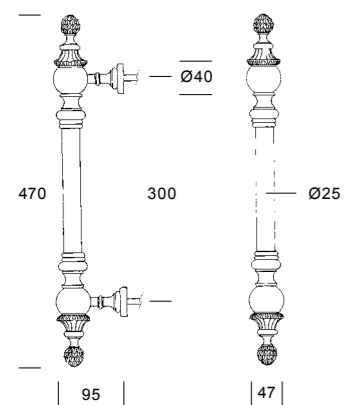

3034

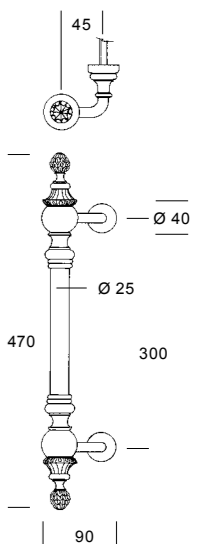



# MADRAS

Stile: Chippendale



Stile: Louis XV



# GULLIVER



3067

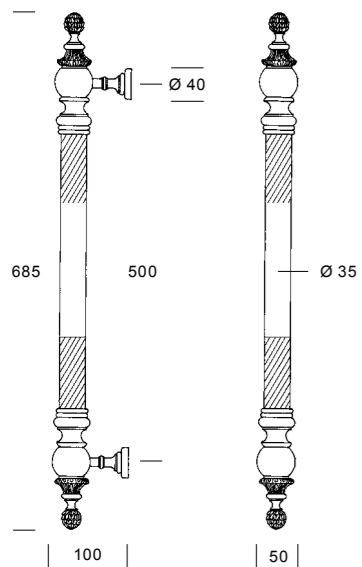

3039/A



3039/B

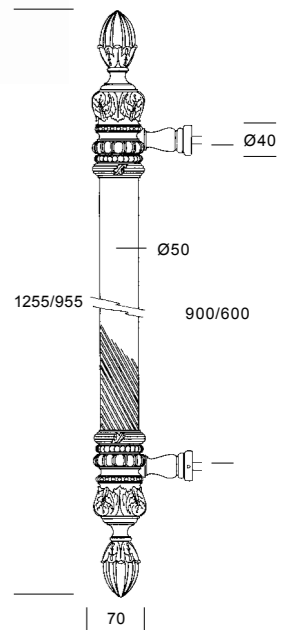



Stile: Romanico



LION



3037

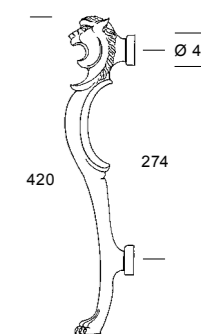



Stile: Fiorentino



**KING**



3038

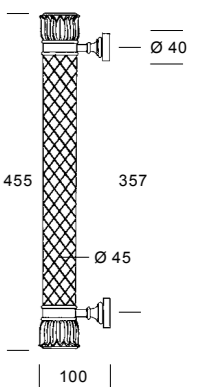



Stile: Fiorentino



PRINCE

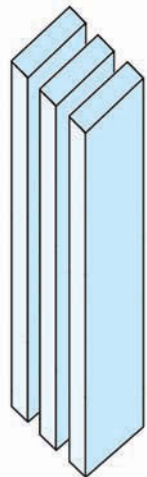

La modalità per ottenere un cristallo cilindrico del diametro di 45 mm con caratteristiche di ottima trasparenza consiste nell'assemblare 3 lastre del tipo "extra chiaro" con speciali colle e trattamenti termici.

*The way to get a cylindrical crystal of the diameter of 45 mm with characteristics of good transparency consists of assembling 3 plates of the type "extra clear" with special neck and thermal treatments.*

Tale pezzo viene poi rettificato con un macchinario unico al mondo che ne lavora la superficie.

*Such piece is corrected then with a worldwide unique machinery that works the surface of it.*

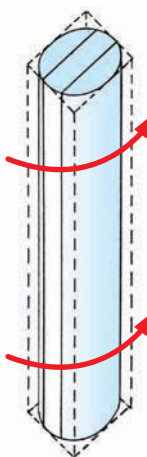

La lucidatura e molatura eseguite a mano da esperti artigiani conferiscono unicità al prodotto.

*The polish and machining performed by hand by expert artisans confer oneness to the product.*

Pertanto, eventuali leggere imperfezioni non sono da ritenersi difetti, ma parte integrante di una lavorazione eseguita manualmente nella maggior parte dei processi di lavorazione.

*So, possible little imperfections are not to consider defects but integral part of the workmanship manually performed in the greatest part of the process of manufacture.*



3099

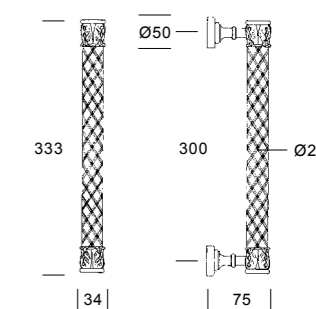



# BOULOGNE

Stile: Impero



Stile: Impero



# DESSAN



3060

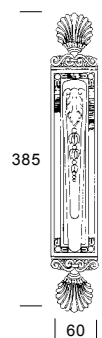

3061

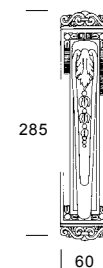



ALAIS

Stile: Arabesco



Stile: Luigi Filippo - fine 1700



MILSE



3062



405

65

3063

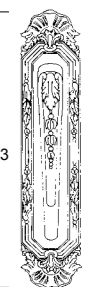

353

73

NEKLA

Stile: Chippendale



Stile: Louis XV

SEOUL



3064



360

| 77 |

3065

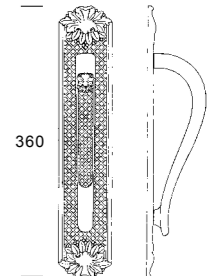

360

| 70 | | 80 |

BYBLOS

Stile: Neoclassico



Stile: Tardo '700

SPARTA



3066

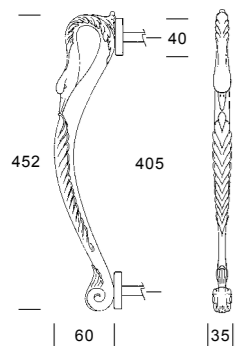

3071

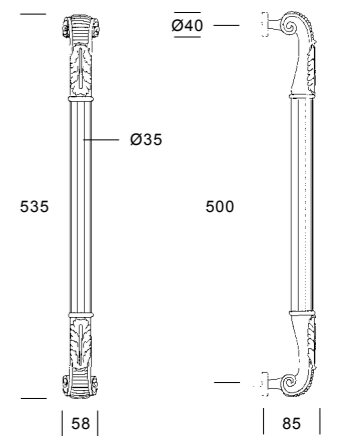



# RHODUS

Stile: Tardo '700



Stile: Tardo '700



# CORINTHUS



3068

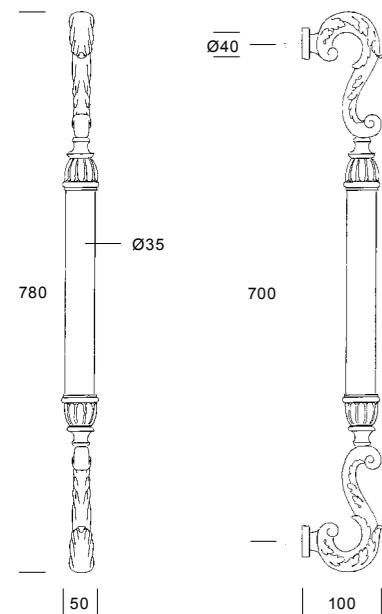

3069

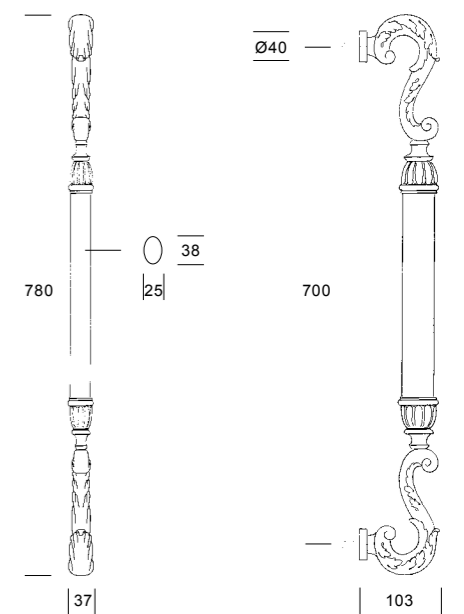



# POMOLI DOOR KNOB





# Impronte

# AMMONITE

Giacomo Benevelli



Ammonite, Encrinus, Cimbius e Cymbium sono il punto di vista di un artista che si interroga sul rapporto fra la produzione industriale e le origini della nostra civiltà. Come fossili moderni, questi oggetti riportano nel presente le forme della natura primordiale, simboli e punti di contatto fra la tecnologia e la vita organica. Giacomo Benevelli, scultore fra i più noti, ha sempre riproposto nelle sue opere e monumenti pubblici quelle forme della natura che lo hanno affascinato.

*Ammonite, Encrinus, Cimbius and Cymbium are the point of view of an artist who questions the relationship between industrial production and the origins of our civilization.*

*As modern fossils, these objects bring forms of primordial nature into the present, as symbols and points of contact between technology and organic life.*

*Giacomo Benevelli, one among the most popular sculptors, always repeated in his works and public monuments those forms of nature that fascinated him.*

8025 

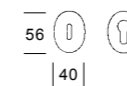
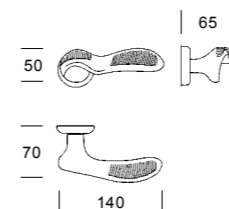



# AMMONITE Impronte



8026

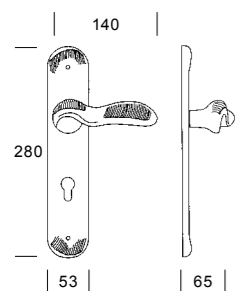

# Impronte AMMONITE



8029/A

8029/B

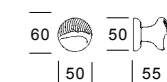
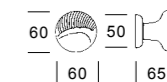



8030

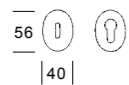
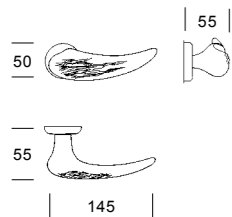

8031

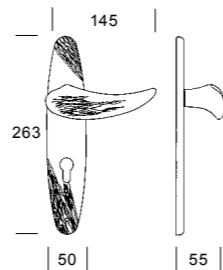

8034

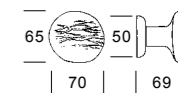





# CIMBIUS Impronte



8035

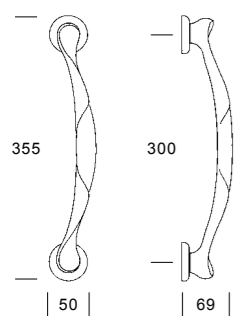

# Impronte CYMBIUM



8036

